

Industrial air cooler DVS

Cooling and working rooms

Cu/Al - R404A



GEA Heat Exchangers

Goedhart



Goedhart DVS

The Goedhart DVS range of dual discharge ceiling mounted air coolers consists of 162 types with capacities between 3,1 and 151.7 kW. The aircoolers are especially suitable for cooling and working room applications. The height of the aircooler is low, so the maximum space in the chill room can be utilised. The coil block is standard build from aluminium end plates, copper tubes and aluminium fins. The fans are arranged for blow-through or draw-through air configuration (please state which is required when ordering). The modular design incorporates 5 different sizes of fan, with model options of up to 6 fans per cooler.

Coil execution

- Tube pitch : 50x50 mm straight
- Fin spacings : 4, 7, 10 mm
- Material : 15 mm o.d. copper tubes
- : aluminium HT-fins
- Goedhart DVS coil blocks have copper tubes mechanically expanded into fully collared aluminium fins, providing excellent thermal contact. All evaporator coils are pressure tested to 30 bars (lower by coolants) and supplied with a light overpressure charge.
- The coolers are suitable for the most commonly used refrigerants/coolants with the exception of NH3.

Type description

DVS 66457

Number of rows deep

Fin spacing

Number of fans

Fan diameter in cm

Casing

- Construction for ceiling mounting
- Casing material of galvanized sheet steel
- Finishing is standard white epoxy spray (RAL 9003)
- Bend/header protection by end covers, easy removed for maintenance
- 2 Hinged drip trays underneath each coil block.
- Defrost by hot gas spiral or electric defrost elements will be fixed to the bottom side of the coil.

General range features

Capacity

The listed nominal cooling capacities are based on R404A, DT1 and DTM and a RH of 85%.

Influence of coating on capacity

The use of coated fins, or of a fully coated coil will result in a capacity decrease of approximately 3%

Capacity optimisation

Since Goedhart tries to limit stock products, we are capable of optimising the circuitry of our evaporators. In order to do this, the following information is needed :

- Design capacity
- Air volume
- Refrigerant
- Air on temperature
- Evaporating temperature
- Liquid temperature before expansion valve.

Sound data

The mean sound pressure (LpA @ 3m ± 2 dB (A)) each air cooler is a calculated indication value according to the EN13487 standard parallel pipe. Goedhart uses the fan manufacturer's sound power level (LwA) at the inlet side of the fan. Changes to or by the fan or the product, affect the sound, in these cases, consult the manufacturer for the new indication value. In critical sound requirements, we advise you to consult an expert.

Defrost systems

For room temperatures where ice-build up can be expected and where the coil can not be defrosted by the room air, electric or hot gas defrost is necessary

Electrical defrost

On request Goedhart DVS can be provided with electrical defrost. The stainless steel heating elements are fitted in the coil block within aluminium tubes, which forms a highly conductive medium between the heaters and the fins. In the drip tray heater elements are fitted to the underside of the aluminium inner tray. The elements are rated for 220/240 V and are connected (IP55) for 380/415 V (with neutral) supply. The heater elements in the coil block are removable from the bend side, whilst the tray heater elements can be removed once the outer tray has been removed.

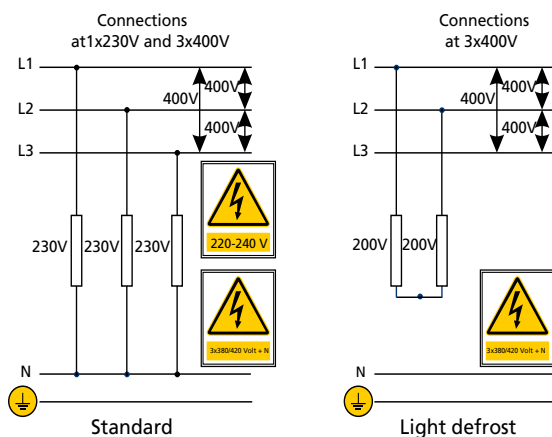

Hot gas defrost

The coil block is suited for hot gas defrost (hot gas supply through the suction header). The drip tray can be provided with a copper hot gas spiral. This is enclosed in aluminium profiles that are rigidly secured to the under side of the aluminium inner drip tray

Accessories:

- Standard accessories for the Goedhart DVS aircoolers are:
- electric, hotgas defrost system.
 - insulation in the space between the inner and outer drip tray.
 - insulated hygienic polyester drip tray.
 - insulated fanplate
 - hinged fan plate
 - single phase motors

The accessories are included in the price list.

Optional extras:

Various optional extras for the Goedhart DVS are available, price and delivery upon request:

- insulation discs
- 60 Hz motors
- water defrost system
- glycol/water/etc. cooling mediums
- stainless steel casing
- other fin spacings
- other fans (when external pressure is requested)

Mounting and Maintenance

Goedhart DVS is delivered on a wooden frame. When on the frame, Goedhart DVS can be handled by forklift truck, which makes positioning and installation simple. Refer to our maintenance and installation manual.

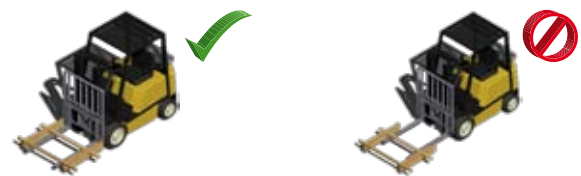

Fans

The manufacturer of the fans is Süd Electric (we reserve the right to alter the manufacturer). The fans have glass fibre reinforced polypropylene impellers. The motors are available for 400V-50Hz-3 phase or 230V-50Hz-1 phase electrical supply. 2-Speed regulation can be achieved at 400/690V-50Hz-3 phase by using a D-Y reconnection (fig. 1). 3 Phase motors are suitable for a frequency controller (A sinus filter is needed, fig. 2). 1 Phase motors are suitable for phase control and transformer. The motors are standard executed with a thermo contact. The fans are suitable for operation in air temperature applications between -40 oC and +45 oC. When the air temperature is lower then -40 °C , special fans are needed. These speciale fans have a longer delivery time. The technical data in the table below are the same as on the motor name plates and is valid for an air temperature of +40 °C.

For air temperatures lower then +40 oC, the current amperage can be calculated by using the diagram multiplication factor, suitable thermal overloads can then be selected.

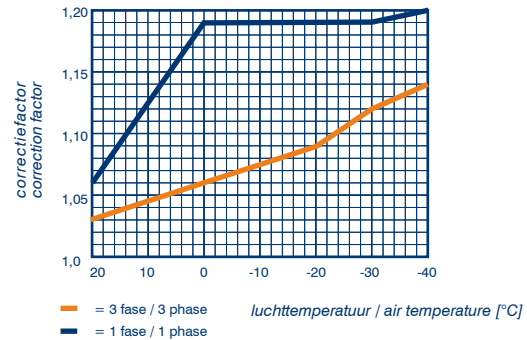

Three phase - 50 Hz

Fan type	Δ					Y			Protection class*	Fan heating
	Tension	Speed	Input	FLC	Sound power indication each fan LwA (+/-2dB(A))	Speed	Input	FLC		
	V	min ⁻¹	Watt	A	dB(A)	min ⁻¹	Watt	A		

4 pole motor (n=1500 rpm nom.)

400-32°	3x400/690	1350	250	0.60	74	1050	150	0.30	IP44	460
450-32°	3x400/690	1350	400	0.85	78	1050	300	0.50	IP44	580
500-40°	3x400/690	1380	880	1.90	85	1050	660	1.15	IP44	580
560-36°	3x400/690	1300	1250	2.30	85	1000	750	1.30	IP66	700
630-32°***	3x400/690	1300	1250	2.30	86	1000	750	1.30	IP66	820
630-28°***	3x230/400				88	1400	1400	2.50	IP66	820

6 pole motor (n=1000 rpm nom.)

400-28°	3x400/690	900	105	0.33	63	750	65	0.13	IP44	460
450-32°	3x400/690	900	180	0.40	69	750	120	0.20	IP44	580
500-40°	3x400/690	900	500	1.00	81	760	350	0.65	IP44	580
560-32°	3x400/690	880	680	1.60	75	680	400	0.90	IP66	700
630-36°	3x400/690	880	680	1.60	80	680	400	0.90	IP66	820

Single phase - 50 Hz

Ventilator type	Speed	Input	FLC	Protection class*
	min ⁻¹	Watt	A	

4 pole motor (n=1500 rpm nom.)

400-32°	1350	450	1.95	IP44
450-32°	1350	450	1.95	IP44
500-40°	1330	700	3.40	IP44
560-36°	1350	920	4.00	IP66
630-32°	1350	1300	7.10	IP66

6 pole motor (n=1000 rpm nom.)

400-28°	900	250	1.10	IP44
450-32°	900	250	1.10	IP44
500-40°	900	400	1.75	IP44
560-32°	870	700	3.40	IP66
630-36°	870	700	3.40	IP66

*= IP44 motors also available in IP66 execution (extra price)

**= Only cooling conditions

***= Only freezing conditions

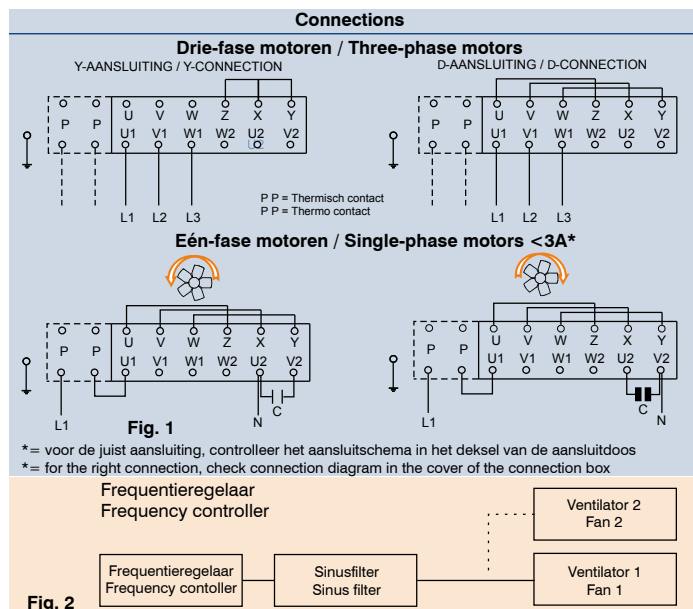

Correction factors

Capacities at DTM:

The capacities are based on R404A direct expansion and the difference between the mean air temperature and the evaporation temperature (DTM). The evaporation temperature is the saturated temperature corresponding to the pressure at the suction outlet of the cooler. The nominal capacities are based on evaporation temperatures of -5 °C, a DTM of 7 K and light frosting. Capacities for other mediums and systems are available upon request.

Correction factors for various mean air temperatures and evaporation temperatures (DTM) are as indicated in the tables below. The requested capacity must be multiplied by a correction factor from one of these tables.

$$Q_{\text{nominal}} = \text{factor} \times Q_{\text{requested}}$$

Capacities at DT1:

Hereby the capacities are based on R404A direct expansion and DT1. DT1 is the difference between air-on temperature and the evaporation temperature of the cooler. The evaporation temperature is the saturated temperature corresponding to the pressure at the suction outlet of the cooler. The nominal capacities are based on evaporation temperatures of -8 °C and DT1=8K and light frosting. Capacities for other mediums and systems are available upon request.

Correction factors for various air-on temperatures and temperature differences (DT1) are as indicated in the table below. The requested capacity must be multiplied by a correction factor from the table, so that a cooler with the resulting nominal capacity can be chosen from the selection tables.

$$Q_{\text{nominal}} = \text{factor} \times Q_{\text{requested}}$$

R404A light frost = 0.2 mm RH = 85%

DTM K	Evaporation temperature (°C)						
	0	-2,5	-5	-7,5	-10	-12,5	-15
6	1.20	1.23	1.26	1.28	1.31	1.32	1.33
7	0.96	0.98	1.00	1.03	1.04	1.07	1.08
8	0.79	0.82	0.84	0.85	0.87	0.88	0.88
9	0.68	0.70	0.71	0.72	0.75	0.77	0.77
10	0.58	0.59	0.62	0.64			

Prices on request due to divergent circuits

DT1 K	Evaporation temperature (°C)						
	0	-2,5	-5	-7,5	-10	-12,5	-15
6	1.40	1.43	1.45	1.48	1.51	1.54	1.56
7	1.12	1.15	1.18	1.20	1.22	1.24	1.25
8	0.93	0.95	0.97	1.00	1.01	1.03	1.05
9	0.78	0.81	0.83	0.85	0.87	0.88	0.89
10	0.68	0.70	0.72	0.74	0.75	0.76	0.78
11	0.60	0.62	0.63	0.65			

Prices on request due to divergent circuits

 = calculated without frosting

 = calculated without frosting

R404A normal frost = 0.5 mm RH= 85%

DTM K	Evaporation temperature (°C)						
	0	-2,5	-5	-7,5	-10	-12,5	-15
6		1.37	1.41	1.43	1.46	1.47	1.49
7		1.10	1.13	1.15	1.17	1.19	1.20
8		0.92	0.94	0.96	0.98	0.99	1.00
9			0.80	0.82	0.83	0.84	0.88
10			0.69	0.71	0.74	0.74	0.75
11			0.62	0.63	0.64		

Prices on request due to divergent circuits

DT1 K	Evaporation temperature (°C)						
	0	-2,5	-5	-7,5	-10	-12,5	-15
6		1.57	1.59	1.62	1.64	1.67	1.69
7		1.26	1.28	1.31	1.33	1.35	1.37
8		1.05	1.07	1.09	1.11	1.13	1.14
9			0.91	0.93	0.95	0.96	0.97
10			0.79	0.81	0.82	0.84	0.85
11			0.70	0.71	0.82	0.74	0.75
12			0.62	0.64	0.65		

Prices on request due to divergent circuits

ATTENTION !!!

When making your selection, pay attention to the ratio between the airvolume and capacity. A low volume to capacity ratio results in a wide temperature drop across the coil which cause to dry out (especially on coils with a high number of rows deep).

The correction factors on this page have been calculated using a varying SHR (ratio of sensible heat load / total heat load). The chart left indicates the SHR values used in the calculations, in which dt is the difference between the air and evaporation temperatures. The SHR values have been based on entering air with a relative humidity of 85%.

Example:

- $t_o = -10$ °C and dt = 10 K resultant SHR value is 0.70
- $t_o = -10$ °C and dt = 5 K resultant SHR value is 0.82
- $t_o = -30$ °C and dt = 10 K resultant SHR value is 0.84
- $t_o = -30$ °C and dt = 5 K resultant SHR value is 0.98

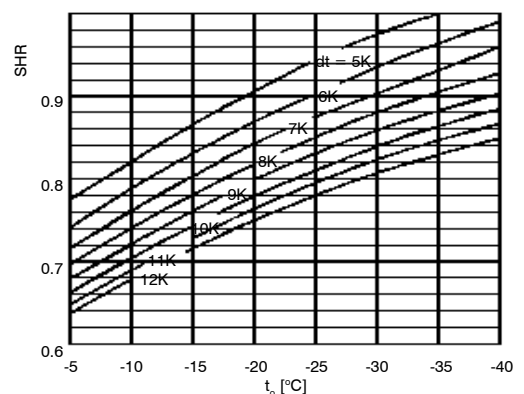

DVS 4mm Technical data

Type DVS	3x400V-50H-4pole (1500 min ⁻¹ nom.)				3x400V-50H-6pole (1000 min ⁻¹ nom.)				Surface	Internally volume	Weight	Dimensions							Connections			
	R404A		Air volume	LpA @ 3 m (+/-2 dB(A))**	R404A		Air volume	LpA @ 3 m (+/-2 dB(A))**				L	B	H	E1	E2	E3	E4	Refrigerant		Hot gas	Drain
	DTM = 7K Air mean = +2°C	DT1 = 8K (SC2) Air on = 0°C			DTM = 7K Air mean = +2°C	DT1 = 8K (SC2) Air on = 0°C													in	out		
	kW	kW	m ³ /h	dB(A)	kW	kW	m ³ /h	dB(A)				mm	mm	mm	mm	mm	mm	mm	mm	mm	mm	NW"

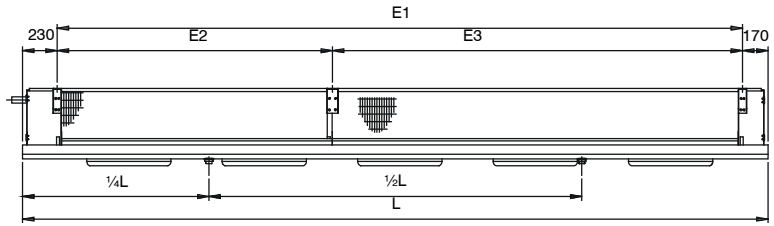
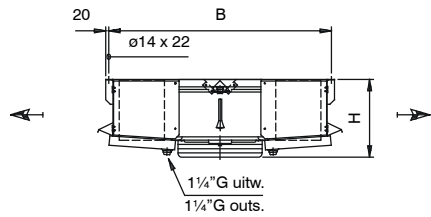

4.1.40.4	5,6	4,9	3082	52	5,1		1892	41	39	6	100	1056	1180	420	656				15	15	4x19	2x1 1/4"
6.1.40.4	9,2	6,6	2837	52	7,6		1790	41	58	10	120	1056	1380	420	656				22	12	4x19	2x1 1/4"
4.1.45.4	9,2	7,8	4610	56	7,8		2901	47	52	8	114	1056	1230	520	656				22	12	4x19	2x1 1/4"
6.1.45.4	12,9	9,3	4239	56	10,4		2632	47	78	12	140	1056	1430	520	656				22	12	4x19	2x1 1/4"
4.1.50.4	11,6	10,2	6946	63	10,6		4599	59	78	12	147	1356	1280	520	956				22	12	4x19	2x1 1/4"
6.1.50.4	19,2	14,5	6527	63	16,5		4315	59	117	18	182	1356	1480	520	956				28	16	4x19	2x1 1/4"
4.1.56.4	19,2	16,4	9904	63	16,7		6294	53	108	16	182	1456	1340	620	1056				28	16	4x19	2x1 1/4"
6.1.56.4	27,3	20,3	9381	63	22,7		5942	53	162	24	226	1456	1540	620	1056				35	16	4x19	2x1 1/4"
4.1.63.4	22,1	19,0	12071	63	20,3		8820	58	130	20	203	1456	1410	720	1056				35	16	4x19	2x1 1/4"
6.1.63.4	32,6	24,4	11387	63	28,2		8283	58	195	30	254	1456	1610	720	1056				35	16	4x19	2x1 1/4"

4.2.40.4	13,2	10,9	6152	55	11,0		3779	44	77	12	154	1656	1180	420	1256				22	12	4x19	2x1 1/4"
6.2.40.4	18,3	13,2	5660	55	15,1		3574	44	116	18	191	1656	1380	420	1256				28	12	4x19	2x1 1/4"
4.2.45.4	18,3	15,5	9206	59	15,6		5791	50	103	16	178	1656	1230	520	1256				28	16	4x19	2x1 1/4"
6.2.45.4	25,6	18,5	8458	59	20,6		5250	50	155	24	222	1656	1430	520	1256				35	16	4x19	2x1 1/4"
4.2.50.4	24,7	21,4	13882	66	22,4		9191	62	155	24	246	2256	1280	520	1856				35	16	4x19	2x1 1/4"
6.2.50.4	39,4	28,8	13039	66	33,1		8621	62	233	34	306	2256	1480	520	1856				35	16	4x19	2x1 1/4"
4.2.56.4	39,7	33,2	19794	66	33,7		12580	56	216	32	304	2456	1340	620	2056				42	16	4x19	2x1 1/4"
6.2.56.4	55,8	40,9	18745	66	45,7		11873	55	324	48	386	2456	1540	620	2056				42	22	4x19	2x1 1/4"
4.2.63.4	46,3	39,4	24125	66	42,4		17627	60	259	38	341	2456	1410	720	2056				42	16	4x19	2x1 1/4"
6.2.63.4	65,5	49,4	22752	66	58,3		16550	60	388	58	436	2456	1610	720	2056				42	22	4x19	2x1 1/4"

4.3.45.4	24,7	21,3	13799	61	22,1		8679	51	155	24	244	2256	1230	520	1856				35	16	4x19	2x1 1/4"
6.3.45.4	39,0	28,4	12678	61	31,7		7868	51	233	34	304	2256	1430	520	1856				35	16	4x19	2x1 1/4"
4.3.50.4	42,9	35,7	20816	67	37,3		13783	63	233	34	344	3156	1280	520	2756				42	16	4x19	2x1 1/4"
6.3.50.4	60,0	43,6	19551	67	50,3		12926	63	349	52	435	3156	1480	520	2756				42	22	4x19	2x1 1/4"
4.3.56.4	58,7	49,6	29685	67	51,2		18864	57	323	48	430	3456	1340	620	3056	1028	2028		54	22	4x19	2x1 1/4"
6.3.56.4	82,8	62,1	28111	67	69,4		17803	57	485	72	546	3456	1540	620	3056	1028	2028		54	22	4x19	2x1 1/4"
4.3.63.4	70,9	59,9	36180	67	64,6		26433	62	388	58	481	3456	1410	720	3056	1028	2028		54	22	4x19	2x1 1/4"
6.3.63.4	99,7	74,9	34117	67	88,7		24816	62	582	86	617	3456	1610	720	3056	1028	2028		54	22	4x19	2x1 1/4"

Pay attention to the relation capacity / air volume !!

* Sound pressure indication (LpA) at 3 m distance each air cooler (+/- 2 dB(A)), free field conditions, according EN13487

DVS 4mm Technical data

Type DVS	3x400V-50H-4pole (1500 min ⁻¹ nom.)				3x400V-50H-6pole (1000 min ⁻¹ nom.)				Dimensions								Connections					
	R404A		Air volume	LpA @ 3 m (+/-2 dB(A))**	R404A		Air volume	LpA @ 3 m (+/-2 dB(A))**	Surface	Internally volume	Weight	L	B	H	E1	E2	E3	E4	Refrigerant			Drain
	DTM = 7K Air mean = +2°C	DT1 = 8K (SC2) Air on = 0°C			DTM = 7K Air mean = +2°C	DT1 = 8K (SC2) Air on = 0°C													in	out	Hot gas	
	kW	kW	m ³ /h	dB(A)	kW	kW	m ³ /h	dB(A)	m ²	dm ³	kg	mm	mm	mm	mm	mm	mm	mm	mm	mm	mm	mm

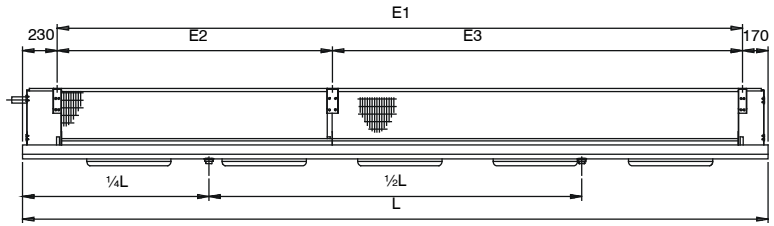
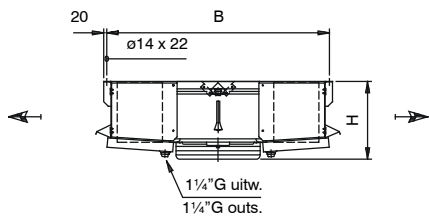

4.4.45.4	37,7	31,2	18394	62	31,5	11570	53	207	30	309	2856	1230	520	2456				42	16	4x19	2x1 1/4"
6.4.45.4	52,1	36,9	16897	62	41,2	10486	53	310	46	391	2856	1430	520	2456				42	16	4x19	2x1 1/4"
4.4.50.4	51,4	44,0	27751	68	46,3	18375	64	310	46	447	4056	1280	520	3656	1828	1828		42	16	4x19	2x1 1/4"
6.4.50.4	80,7	58,4	26062	68	67,4	17231	64	466	68	564	4056	1480	520	3656	1828	1828		54	22	4x19	2x1 1/4"
4.4.56.4	81,0	67,3	39575	68	68,4	25150	58	431	64	558	4456	1340	620	4056	2028	2028		54	22	4x19	2x1 1/4"
6.4.56.4	113,7	83,2	37475	68	93,2	23734	58	647	94	713	4456	1540	620	4056	2028	2028		54	22	4x19	2x1 1/4"
4.4.63.4	95,1	80,5	48235	68	86,8	35239	63	517	76	626	4456	1410	720	4056	2028	2028		54	22	4x19	2x1 1/4"
6.4.63.4	134,1	100,5	45482	68	119,2	33082	63	776	114	806	4456	1610	720	4056	2028	2028		64	28	4x19	2x1 1/4"

4.5.50.4	70,2	58,0	34685	69	59,0	22967	65	388	58	545	4956	1280	520	4556	1828	2728		54	22	4x19	4x1 1/4"
6.5.50.4	97,7	72,1	32575	69	81,9	21536	65	582	86	690	4956	1480	520	4556	1828	2728		54	22	4x19	4x1 1/4"
4.5.56.4	101,6	84,4	49466	69	85,7	31434	59	539	78	684	5456	1340	620	5056	2028	3028		54	22	4x19	4x1 1/4"
6.5.56.4	142,6	103,9	46838	69	116,2	29665	58	808	118	874	5456	1540	620	5056	2028	3028		64	28	4x19	4x1 1/4"
4.5.63.4	122,6	102,1	60290	69	109,3	44046	63	647	94	766	5456	1410	720	5056	2028	3028		64	28	4x19	4x1 1/4"
6.5.63.4	171,9	123,7	56847	69	149,1	41348	63	970	142	987	5456	1610	720	5056	2028	3028		64	28	4x19	4x1 1/4"

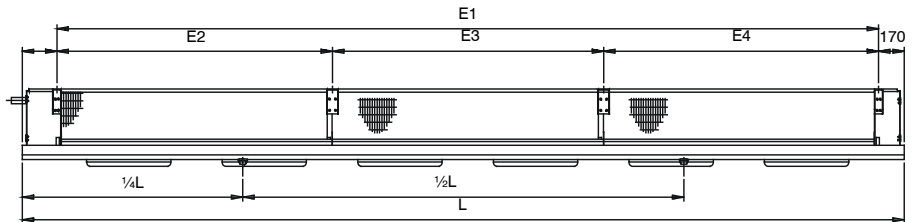
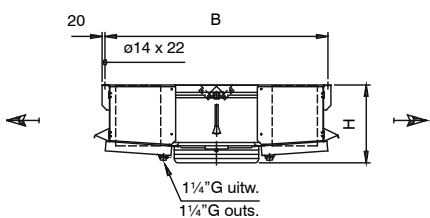

4.6.50.4	87,3	72,3	41620	69	75,6	27558	65	465	68	643	5856	1280	520	5456	1828	1800	1828	54	22	4x19	4x1 1/4"
6.6.50.4	122,0	88,0	39087	69	101,8	25842	65	698	102	817	5856	1480	520	5456	1828	1800	1828	54	28	4x19	4x1 1/4"
4.6.56.4	119,5	100,6	59356	69	103,9	37720	59	646	94	811	6456	1340	620	6056	2028	2000	2028	64	22	4x19	4x1 1/4"
6.6.56.4	168,5	125,5	56202	69	140,8	35594	59	970	142	1039	6456	1540	620	6056	2028	2000	2028	64	28	4x19	4x1 1/4"
4.6.63.4	144,0	121,6	72343	70	130,9	52853	64	776	114	910	6456	1410	720	6056	2028	2000	2028	64	28	4x19	4x1 1/4"
6.6.63.4	203,0	151,6	68212	70	180,2	49615	64	1164	170	1175	6456	1610	720	6056	2028	2000	2028	76	28	4x19	4x1 1/4"

Pay attention to the relation capacity / air volume !!

* Sound pressure indication (LpA) at 3 m distance each air cooler (+/- 2 dB(A)) , free field conditions, according EN13487

DVS 7mm Technical data

Type DVS	3x400V-50H-4pole (1500 min ⁻¹ nom.)						3x400V-50H-6pole (1000 min ⁻¹ nom.)						Dimensions							Connections			
	R404A		Air volume	LpA @ 3 m (+/-2 dB(A))**	R404A		Air volume	LpA @ 3 m (+/-2 dB(A))**	Surface	Internally volume	Weight	L	B	H	E1	E2	E3	E4	Refrigerant				
	DTM = 7K Air mean = +2°C	DT1 = 8K (SC2) Air on = 0°C			DTM = 7K Air mean = +2°C	DT1 = 8K (SC2) Air on = 0°C													in	out	Hot gas	Drain	
	kW	kW	m ³ /h	dB(A)	kW	kW	m ³ /h	dB(A)	m ²	dm ³	kg	mm	mm	mm	mm	mm	mm	mm	mm	mm	mm	mm	mm

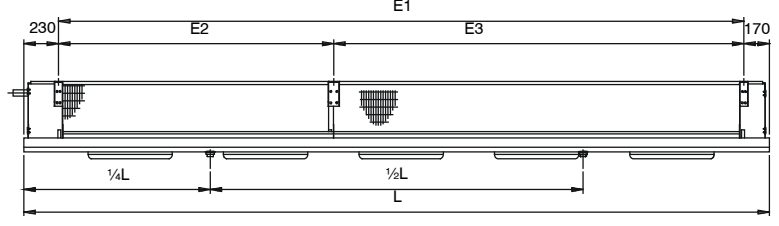
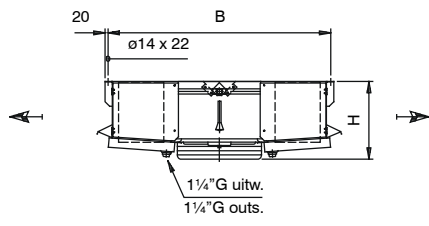

3.4.45.7	18,3	18,1	21047	62	15,5	14,8	13459	53	91	24	244	2856	1130	520	2456						28	16	4x19	2x1/4"
4.4.45.7	21,5	21,2	20551	62	19,0	17,1	13124	53	121	30	274	2856	1230	520	2456						35	16	4x19	2x1/4"
6.4.45.7	35,1	30,4	19624	62	29,1	23,5	12467	52	182	46	338	2856	1430	520	2456						42	16	4x19	2x1/4"
8.4.45.7	40,3	33,5	18791	62	34,6	26,4	11859	52	243	60	400	2856	1630	520	2456						42	16	4x19	2x1/4"
3.4.50.7	27,3	27,0	30388	68	23,5	22,3	20233	64	136	34	348	4056	1180	520	3656	1828	1828				35	16	4x19	2x1/4"
4.4.50.7	36,2	34,0	29926	68	30,9	27,7	19898	64	182	46	395	4056	1280	520	3656	1828	1828				42	16	4x19	2x1/4"
6.4.50.7	52,9	45,6	29029	68	44,6	35,9	19259	64	273	68	485	4056	1480	520	3656	1828	1828				42	22	4x19	2x1/4"
8.4.50.7	68,2	54,4	28174	68	56,8	41,8	18666	64	365	90	576	4056	1680	520	3656	1828	1828				54	22	4x19	2x1/4"
3.4.56.7	38,0	38,2	42869	68	30,9	29,9	27329	58	190	48	428	4456	1240	620	4056	2028	2028				42	22	4x19	2x1/4"
4.4.56.7	49,5	46,5	42282	68	42,3	37,7	26949	58	253	64	485	4456	1340	620	4056	2028	2028				42	22	4x19	2x1/4"
6.4.56.7	73,4	63,4	41159	68	61,2	49,5	26210	58	380	94	604	4456	1540	620	4056	2028	2028				54	22	4x35	2x1/4"
8.4.56.7	93,8	76,0	40100	68	78,1	57,8	25502	58	507	126	720	4456	1740	620	4056	2028	2028				54	22	4x35	2x1/4"
3.4.63.7	46,0	46,2	52361	68	40,8	39,3	38505	63	228	58	472	4456	1310	720	4056	2028	2028				42	22	4x35	2x1/4"
4.4.63.7	60,7	58,0	51660	68	53,8	49,0	37951	63	304	76	539	4456	1410	720	4056	2028	2028				54	22	4x35	2x1/4"
6.4.63.7	88,7	76,9	50266	68	78,2	65,0	36847	63	456	114	674	4456	1610	720	4056	2028	2028				54	22	4x35	2x1/4"
8.4.63.7	114,6	92,0	48914	68	100,2	76,6	35776	63	608	150	807	4456	1810	720	4056	2028	2028				64	28	4x35	2x1/4"

3.5.50.7	34,5	34,2	37985	69	29,3	28,0	25291	65	171	44	423	4956	1180	520	4556	1828	2728				42	16	4x35	4x1/4"
4.5.50.7	42,4	39,7	37406	69	37,4	33,6	24871	65	228	58	480	4956	1280	520	4556	1828	2728				42	16	4x35	4x1/4"
6.5.50.7	66,6	57,3	36283	69	55,6	44,5	24074	65	342	86	591	4956	1480	520	4556	1828	2728				54	22	4x35	4x1/4"
8.5.50.7	80,0	65,6	35215	69	68,9	52,2	23330	65	456	114	704	4956	1680	520	4556	1828	2728				54	22	4x35	4x1/4"
3.5.56.7	47,8	48,0	53583	69	40,5	38,3	34161	59	237	60	520	5456	1240	620	5056	2028	3028				42	22	4x35	4x1/4"
4.5.56.7	63,4	60,2	52853	69	51,7	46,6	33686	59	316	78	593	5456	1340	620	5056	2028	3028				54	22	4x35	4x1/4"
6.5.56.7	92,8	80,1	51447	69	77,2	62,0	32761	58	475	118	738	5456	1540	620	5056	2028	3028				54	22	4x35	4x1/4"
8.5.56.7	119,9	94,8	50121	69	95,3	70,4	31875	58	633	156	881	5456	1740	620	5056	2028	3028				64	28	4x35	4x1/4"
3.5.63.7	57,7	56,8	65451	69	51,7	49,7	48132	63	285	72	575	5456	1310	720	5056	2028	3028				54	22	4x35	4x1/4"
4.5.63.7	76,3	71,9	64572	69	68,1	62,1	47436	63	380	94	657	5456	1410	720	5056	2028	3028				54	22	4x35	4x1/4"
6.5.63.7	111,7	97,0	62829	69	99,0	81,8	46055	63	570	142	823	5456	1610	720	5056	2028	3028				64	28	4x35	4x1/4"
8.5.63.7	144,5	116,4	61137	69	126,8	96,0	44717	63	760	188	989	5456	1810	720	5056	2028	3028				64	28	4x35	4x1/4"

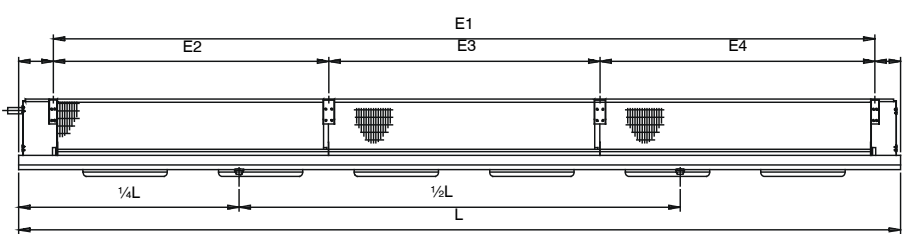
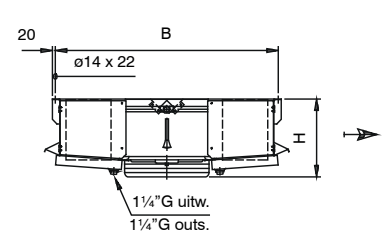

3.6.50.7	40,3	40,1	45579	69	35,2	33,2	30348	65	205	52	498	5856	1180	520	5456	1828	1828	1828				42	16	4x35	4x1/4"
4.6.50.7	51,5	49,9	44887	69	41,6	38,5	29844	65	273	68	564	5856	1280	520	5456	1828	1800	1828				42	22	4x35	4x1/4"
6.6.50.7	78,0	67,5	43540	69	66,8	54,2	28887	65	410	102	698	5856	1480	520	5456	1828	1800	1828				54	22	4x35	4x1/4"
8.6.50.7	96,7	76,2	42255	69	76,4	59,9	27995	65	547	136	830	5856	1680	520	5456	1828	1800	1828				54	28	4x35	4x1/4"
3.6.56.7	57,5	57,5	64300	69	48,7	46,1	40993	59	285	72	617	6456	1240	620	6056	2028	2000	2028				54	22	4x35	4x1/4"
4.6.56.7	76,0	72,1	63421	69	64,1	57,2	40422	59	380	94	703	6456	1340	620	6056	2028	2000	2028				54	22	4x35	4x1/4"
6.6.56.7	111,3	96,4	61735	69	92,8	74,5	39311	59	570	142	874	6456	1540	620	6056	2028	2000	2028				64	28	4x35	4x1/4"
8.6.56.7	144,0	115,5	60143	69	118,3	86,5	38248	59	760	188	1046	6456	1740	620	6056	2028	2000	2028				64	28	4x35	4x1/4"
3.6.63.7	69,2	69,7	78539	70	60,2	59,2	57758	64	342	86	683	6456	1310	720	6056	2028	2000	2028				54	22	4x35	4x1/4"
4.6.63.7	82,2	87,3	77485	70	79,3	73,1	56923	64	456	114	780	6456	1410	720	6056	2028	2000	2028				54	22	4x35	4x1/4"
6.6.63.7	133,7	115,7	75393	70	115,1	95,7	55265	64	684	170	978	6456	1610	720	6056	2028	2000	2028				64	28	4x35	4x1/4"
8.6.63.7	172,6	136,6	73362	69	147,0	113,9	53658	64	912	226	1174	6456	1810	720	6056	2028	2000	2028				76	28	4x35	4x1/4"

Pay attention to the relation capacity / air volume !!

* Sound pressure indication (LpA) at 3 m distance each air cooler (+/- 2 dB(A)) , free field conditions, according EN13487

DVS 10mm Technical data

Type DVS	3x400V-50H-4pole (1500 min ⁻¹ nom.)				3x400V-50H-6pole (1000 min ⁻¹ nom.)				Surface	Internally volume	Weight	Dimensions							Connections			
	R404A		Air volume	LpA @ 3 m (+/-2 dB(A))*	R404A		Air volume	LpA @ 3 m (+/-2 dB(A))*				L	B	H	E1	E2	E3	E4	Refrigerant			Drain
	DTM = 7K Air mean = +2°C	DT1 = 8K (SC2) Air on = 0°C			DTM = 7K Air mean = +2°C	DT1 = 8K (SC2) Air on = 0°C													in	out	Hot gas	
	kW	kW	m ³ /h	dB(A)	kW	kW	m ³ /h	dB(A)				m ²	dm ³	kg	mm	mm	mm	mm	mm	mm	mm	mm

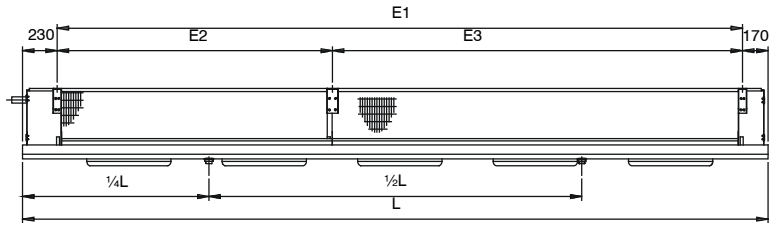
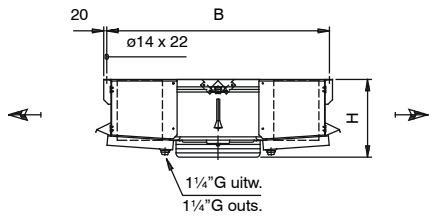

8.1.40.10	6,2	5,4	3352	52	4,6	3,7	2012	41	33	12	124	1056	1580	420	656				16	12	4x19	2x1 1/4"
1.1.40.10	7,5	6,2	3275	52	5,9	4,4	1976	41	41	16	139	1056	1780	420	656				22	12	4x19	2x1 1/4"
8.1.45.10	8,3	7,4	5055	56	7,0	5,8	3223	47	44	16	141	1056	1630	520	656				22	12	4x19	2x1 1/4"
1.1.45.10	10,2	8,4	4921	56	7,7	6,3	3128	47	55	20	161	1056	1830	520	656				22	12	4x19	2x1 1/4"
8.1.50.10	13,1	11,4	7400	63	10,5	8,6	4917	59	66	24	180	1356	1680	520	956				28	12	4x19	2x1 1/4"
1.1.50.10	16,0	13,1	7270	63	13,0	10,1	4824	59	82	30	205	1356	1880	520	956				28	12	4x19	2x1 1/4"
8.1.56.10	18,3	16,0	10469	63	14,7	12,1	6670	53	91	32	219	1456	1740	620	1056				28	12	4x19	2x1 1/4"
1.1.56.10	21,6	17,8	10304	63	17,5	13,8	6562	53	114	40	250	1456	1940	620	1056				28	16	4x19	2x1 1/4"
8.1.63.10	22,1	19,5	12789	63	19,1	16,1	9388	58	109	38	244	1456	1810	720	1056				35	16	4x19	2x1 1/4"
1.1.63.10	27,3	22,6	12584	63	23,2	18,3	9226	58	137	48	280	1456	2010	720	1056				35	16	4x19	2x1 1/4"

8.2.40.10	12,4	10,7	6698	55	9,6	7,8	4022	44	65	24	190	1656	1580	420	1256				22	12	4x19	2x1 1/4"
1.2.40.10	15,1	12,3	6542	55	11,7	8,8	3948	44	82	30	217	1656	1780	420	1256				28	12	4x19	2x1 1/4"
8.2.45.10	16,6	14,8	10099	59	14,0	11,7	6439	50	87	30	218	1656	1630	520	1256				28	16	4x19	2x1 1/4"
1.2.45.10	20,3	17,3	9830	59	16,9	13,2	6246	50	109	38	249	1656	1830	520	1256				28	16	4x19	2x1 1/4"
8.2.50.10	26,1	22,8	14794	66	20,9	17,2	9829	62	131	46	296	2256	1680	520	1856				35	16	4x19	2x1 1/4"
1.2.50.10	32,0	26,2	14530	65	26,0	20,2	9641	61	164	58	340	2256	1880	520	1856				35	16	4x19	2x1 1/4"
8.2.56.10	36,5	32,1	20928	66	29,3	24,1	13336	55	182	64	364	2456	1740	620	2056				42	16	4x19	2x1 1/4"
1.2.56.10	42,3	35,6	20598	66	35,0	27,6	13117	55	228	78	416	2456	1940	620	2056				42	22	4x19	2x1 1/4"
8.2.63.10	44,2	38,9	25568	66	38,2	32,2	18768	60	219	76	405	2456	1810	720	2056				42	16	4x19	2x1 1/4"
1.2.63.10	54,4	45,1	25157	66	46,6	36,7	18443	60	274	94	467	2456	2010	720	2056				42	22	4x35	2x1 1/4"

8.3.45.10	26,4	23,1	15144	61	20,7	17,0	9655	51	131	46	294	2256	1630	520	1856				35	16	4x19	2x1 1/4"
1.3.45.10	32,2	26,5	14738	60	25,6	19,8	9365	51	164	58	338	2256	1830	520	1856				35	16	4x19	2x1 1/4"
8.3.50.10	36,2	31,9	22188	67	30,9	25,8	14740	63	197	68	414	3156	1680	520	2756				42	16	4x19	2x1 1/4"
1.3.50.10	47,4	38,7	21791	67	37,5	29,8	14458	63	246	86	475	3156	1880	520	2756				42	22	4x19	2x1 1/4"
8.3.56.10	55,3	48,1	31390	67	43,4	35,6	20000	57	273	94	511	3456	1740	620	3056	1028	2028		42	22	4x35	2x1 1/4"
1.3.56.10	67,7	55,6	30893	67	52,8	40,2	19672	57	342	118	589	3456	1940	620	3056	1028	2028		54	22	4x35	2x1 1/4"
8.3.63.10	65,9	57,7	38347	67	57,2	48,2	28148	62	328	114	569	3456	1810	720	3056	1028	2028		54	22	4x35	2x1 1/4"
1.3.63.10	81,9	67,5	37729	67	69,7	55,4	27658	62	410	142	659	3456	2010	720	3056	1028	2028		54	22	4x35	2x1 1/4"

Pay attention to the relation capacity / air volume !!

* Sound pressure indication (LpA) at 3 m distance each air cooler (+/- 2 dB(A)), free field conditions, according EN13487

DVS 10mm Technical data

Type DVS	3x400V-50H-4pole (1500 min ⁻¹ nom.)						3x400V-50H-6pole (1000 min ⁻¹ nom.)						Dimensions								Connections			
	R404A		Air volume	LpA @ 3 m (+/-2 dB(A))**	R404A		Air volume	LpA @ 3 m (+/-2 dB(A))**	Surface	Internally volume	Weight	L	B	H	E1	E2	E3	E4	Refrigerant					
	DTM = 7K Air mean = +2°C	DT1 = 8K (SC2) Air on = 0°C			DTM = 7K Air mean = +2°C	DT1 = 8K (SC2) Air on = 0°C													in	out	Hot gas	Drain		
	kW	kW	m ³ /h	dB(A)	kW	kW	m ³ /h	dB(A)	m ²	dm ³	kg	mm	mm	mm	mm	mm	mm	mm	mm	mm	mm	mm	NW"	

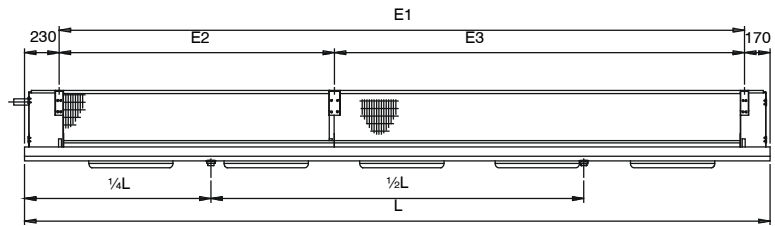
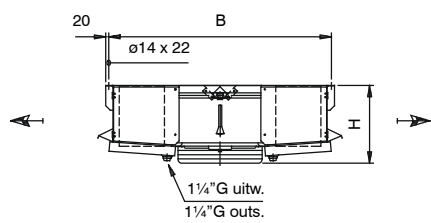

8.4.45.10	34,0	29,9	20187	62	27,9	23,3	12871	52	175	60	372	2856	1630	520	2456				42	16	4x19	2x1 1/4"
1.4.45.10	41,5	34,6	19648	62	33,8	26,4	12483	52	219	76	429	2856	1830	520	2456				42	22	4x19	2x1 1/4"
8.4.50.10	52,4	45,6	29581	68	41,7	34,3	19651	64	262	90	533	4056	1680	520	3656	1828	1828		42	22	4x19	2x1 1/4"
1.4.50.10	64,1	52,6	29051	68	52,1	40,4	19276	64	328	114	613	4056	1880	520	3656	1828	1828		54	22	4x35	2x1 1/4"
8.4.56.10	74,2	64,5	41849	68	58,6	48,2	26666	58	364	126	661	4456	1740	620	4056	2028	2028		54	22	4x35	2x1 1/4"
1.4.56.10	90,8	74,4	41187	68	71,3	55,2	26227	58	456	156	762	4456	1940	620	4056	2028	2028		54	22	4x35	2x1 1/4"
8.4.63.10	89,8	78,2	51128	68	76,7	64,3	37529	63	437	150	737	4456	1810	720	4056	2028	2028		54	22	4x35	2x1 1/4"
1.4.63.10	110,0	90,4	50302	68	93,4	73,4	36874	63	547	188	854	4456	2010	720	4056	2028	2028		54	28	4x35	2x1 1/4"

8.5.50.10	65,4	56,9	36975	69	53,8	44,3	24562	65	328	114	651	4956	1680	520	4556	1828	2728		54	22	4x35	4x1 1/4"
1.5.50.10	80,0	65,9	36312	69	65,3	50,5	24093	65	410	142	748	4956	1880	520	4556	1828	2728		54	22	4x35	4x1 1/4"
8.5.56.10	88,9	78,0	52309	69	73,1	60,4	33331	58	455	156	808	5456	1740	620	5056	2028	3028		54	22	4x35	4x1 1/4"
1.5.56.10	108,9	90,9	51482	69	88,9	69,0	32783	58	569	196	934	5456	1940	620	5056	2028	3028		54	28	4x35	4x1 1/4"
8.5.63.10	112,4	97,8	63906	69	95,0	79,7	46909	63	547	188	901	5456	1810	720	5056	2028	3028		64	28	4x35	4x1 1/4"
1.5.63.10	137,6	112,6	62874	69	115,8	91,7	46091	63	683	234	1045	5456	2010	720	5056	2028	3028		64	28	4x35	4x1 1/4"

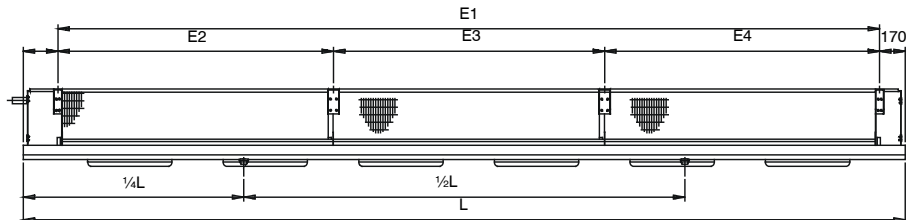
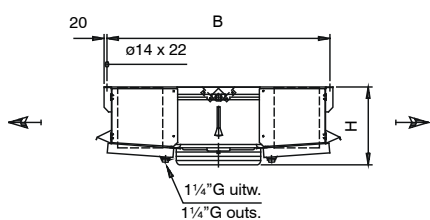

8.6.50.10	73,9	65,0	44368	69	62,7	52,3	29474	65	393	136	767	5856	1680	520	5456	1828	1800	1828	54	22	4x35	4x1 1/4"
1.6.50.10	94,8	77,3	43572	69	76,2	60,0	28911	65	492	170	885	5856	1880	520	5456	1828	1800	1828	54	28	4x35	4x1 1/4"
8.6.56.10	111,5	96,8	62770	69	86,8	71,1	39995	59	547	188	958	6456	1740	620	6056	2028	2000	2028	64	28	4x35	4x1 1/4"
1.6.56.10	136,5	111,4	61777	69	105,5	80,5	39340	59	683	234	1107	6456	1940	620	6056	2028	2000	2028	64	28	4x35	4x1 1/4"
8.6.63.10	133,6	116,6	76686	69	115,6	96,9	56291	64	656	226	1069	6456	1810	720	6056	2028	2000	2028	64	28	4x35	4x1 1/4"
1.6.63.10	165,4	135,3	75447	69	140,9	111,0	55308	64	820	282	1240	6456	2010	720	6056	2028	2000	2028	64	28	4x35	4x1 1/4"

Pay attention to the relation capacity / air volume !!

* Sound pressure indication (LpA) at 3 m distance each air cooler (+/- 2 dB(A)) , free field conditions, according EN13487

DVS Electrical defrost

Type	Fan	Light defrost					Heavy defrost				
		Coil (230V)		Drip tray (200V)		Total	Coil (230V)		Drip tray (200V)		Total
		number	kW	number	kW	kW	number	kW	number	kW	kW



1 fan

3.1.40.f	Ø400	1 (2x)	1.26	1 (2x)	1.36	2.62	2 (2x)	2.52	1 (2x)	1.36	3.88
4.1.40.f		1 (2x)	1.26	1 (2x)	1.36	2.62	2 (2x)	2.52	1 (2x)	1.36	3.88
6.1.40.f		2 (2x)	2.52	1 (2x)	1.36	3.88	3 (2x)	3.78	1 (2x)	1.36	5.14
8.1.40.f		2 (2x)	2.52	1 (2x)	1.36	3.88	3 (2x)	3.78	1 (2x)	1.36	5.14
1.1.40.f		3 (2x)	3.78	1 (2x)	1.56	5.34	4 (2x)	5.04	1 (2x)	1.56	6.60
3.1.45.f	Ø450	2 (2x)	2.52	1 (2x)	1.36	3.88	3 (2x)	3.78	1 (2x)	1.56	5.14
4.1.45.f		2 (2x)	2.52	1 (2x)	1.36	3.88	3 (2x)	3.78	1 (2x)	1.36	5.14
6.1.45.f		2 (2x)	2.52	1 (2x)	1.36	3.88	3 (2x)	3.78	1 (2x)	1.36	5.14
8.1.45.f		2 (2x)	2.52	1 (2x)	1.36	3.88	4 (2x)	5.04	1 (2x)	1.36	6.40
1.1.45.f		3 (2x)	3.78	1 (2x)	1.56	5.34	5 (2x)	6.30	1 (2x)	1.56	7.86
3.1.50.f	Ø500	2 (2x)	3.56	1 (2x)	1.76	5.32	3 (2x)	5.34	1 (2x)	1.76	7.10
4.1.50.f		2 (2x)	3.56	1 (2x)	1.76	5.32	3 (2x)	5.34	1 (2x)	1.76	7.10
6.1.50.f		2 (2x)	3.56	1 (2x)	1.76	5.32	3 (2x)	5.34	1 (2x)	1.76	7.10
8.1.50.f		2 (2x)	3.56	1 (2x)	1.76	5.32	4 (2x)	7.12	1 (2x)	1.76	8.88
1.1.50.f		3 (2x)	5.34	1 (2x)	1.96	7.30	5 (2x)	8.90	1 (2x)	1.96	10.86
3.1.56.f	Ø560	2 (2x)	4.08	1 (2x)	1.96	6.04	3 (2x)	6.12	1 (2x)	1.96	8.08
4.1.56.f		2 (2x)	4.08	1 (2x)	1.96	6.04	3 (2x)	6.12	1 (2x)	1.96	8.08
6.1.56.f		2 (2x)	4.08	1 (2x)	1.96	6.04	3 (2x)	6.12	1 (2x)	1.96	8.08
8.1.56.f		2 (2x)	4.08	1 (2x)	1.96	6.04	4 (2x)	8.16	1 (2x)	1.96	10.12
1.1.56.f		3 (2x)	6.12	1 (2x)	2.14	8.26	5 (2x)	10.20	1 (2x)	2.14	12.34
3.1.63.f	Ø630	2 (2x)	4.08	1 (2x)	1.96	6.04	3 (2x)	6.12	1 (2x)	1.96	8.08
4.1.63.f		2 (2x)	4.08	1 (2x)	1.96	6.04	3 (2x)	6.12	1 (2x)	1.96	8.08
6.1.63.f		2 (2x)	4.08	1 (2x)	1.96	6.04	3 (2x)	6.12	1 (2x)	1.96	8.08
8.1.63.f		3 (2x)	6.12	1 (2x)	1.96	6.04	5 (2x)	10.20	1 (2x)	1.96	12.16
1.1.63.f		3 (2x)	6.12	1 (2x)	2.14	8.26	5 (2x)	10.20	1 (2x)	2.14	12.34



2 fans

3.2.40.f	Ø400	1 (2x)	2.32	1 (2x)	2.14	4.46	2 (2x)	4.64	1 (2x)	2.14	6.78
4.2.40.f		1 (2x)	2.32	1 (2x)	2.14	4.46	2 (2x)	4.64	1 (2x)	2.14	6.78
6.2.40.f		2 (2x)	4.64	1 (2x)	2.14	6.78	3 (2x)	6.96	1 (2x)	2.14	9.10
8.2.40.f		2 (2x)	4.64	1 (2x)	2.14	6.78	3 (2x)	6.96	1 (2x)	2.14	9.10
1.2.40.f		3 (2x)	6.96	1 (2x)	2.34	9.30	4 (2x)	9.28	1 (2x)	2.34	11.62
3.2.45.f	Ø450	2 (2x)	4.64	1 (2x)	2.14	6.78	3 (2x)	6.96	1 (2x)	2.14	9.10
4.2.45.f		2 (2x)	4.64	1 (2x)	2.14	6.78	3 (2x)	6.96	1 (2x)	2.14	9.10
6.2.45.f		2 (2x)	4.64	1 (2x)	2.14	6.78	3 (2x)	6.96	1 (2x)	2.14	9.10
8.2.45.f		2 (2x)	4.64	1 (2x)	2.14	6.78	4 (2x)	9.28	1 (2x)	2.14	11.42
1.2.45.f		3 (2x)	6.96	1 (2x)	2.34	9.30	5 (2x)	11.60	1 (2x)	2.34	13.94
3.2.50.f	Ø500	2 (2x)	7.24	1 (2x)	2.92	10.16	3 (2x)	10.86	1 (2x)	2.92	13.78
4.2.50.f		2 (2x)	7.24	1 (2x)	2.92	10.16	3 (2x)	10.86	1 (2x)	2.92	13.78
6.2.50.f		2 (2x)	7.24	1 (2x)	2.92	10.16	3 (2x)	10.86	1 (2x)	2.92	13.78
8.2.50.f		3 (2x)	7.24	1 (2x)	2.92	10.16	4 (2x)	14.48	1 (2x)	2.92	17.40
1.2.50.f		3 (2x)	10.86	1 (2x)	3.12	13.98	5 (2x)	18.10	1 (2x)	3.12	21.22
3.2.56.f	Ø560	2 (2x)	7.76	1 (2x)	3.34	11.10	3 (2x)	11.64	1 (2x)	3.34	14.98
4.2.56.f		2 (2x)	7.76	1 (2x)	3.34	11.10	3 (2x)	11.64	1 (2x)	3.34	14.98
6.2.56.f		2 (2x)	7.76	1 (2x)	3.34	11.10	3 (2x)	11.64	1 (2x)	3.34	14.98
8.2.56.f		3 (2x)	7.76	1 (2x)	3.34	11.10	4 (2x)	15.52	1 (2x)	3.34	18.86
1.2.56.f		3 (2x)	11.64	1 (2x)	3.52	15.16	5 (2x)	19.40	1 (2x)	3.52	22.92
3.2.63.f	Ø630	2 (2x)	7.76	1 (2x)	3.34	11.10	3 (2x)	11.64	1 (2x)	3.34	14.98
4.2.63.f		2 (2x)	7.76	1 (2x)	3.34	11.10	3 (2x)	11.64	1 (2x)	3.34	14.98
6.2.63.f		2 (2x)	7.76	1 (2x)	3.34	11.10	3 (2x)	11.64	1 (2x)	3.34	14.98
8.2.63.f		3 (2x)	11.64	1 (2x)	3.34	14.98	5 (2x)	19.40	1 (2x)	3.34	22.74
1.2.63.f		3 (2x)	11.64	1 (2x)	3.52	15.16	5 (2x)	19.40	1 (2x)	3.52	22.92



3 fans

3.3.45.f	Ø450	2 (2x)	7.24	1 (2x)	2.92	10.16	3 (2x)	10.86	1 (2x)	2.95	13.78
4.3.45.f		2 (2x)	7.24	1 (2x)	2.92	10.16	3 (2x)	10.86	1 (2x)	2.95	13.78
6.3.45.f		2 (2x)	7.24	1 (2x)	2.92	10.16	3 (2x)	10.86	1 (2x)	2.92	13.78
8.3.45.f		2 (2x)	7.24	1 (2x)	2.92	10.16	4 (2x)	14.48	1 (2x)	2.92	17.40
1.3.45.f		3 (2x)	10.86	1 (2x)	3.12	13.98	5 (2x)	18.10	1 (2x)	3.12	21.22
3.3.50.f	Ø500	4 (2x)	9.84	2 (2x)	4.28	14.12	6 (2x)	14.76	2 (2x)	4.28	19.04
4.3.50.f		4 (2x)	9.84	2 (2x)	4.28	14.12	6 (2x)	14.76	2 (2x)	4.28	19.04
6.3.50.f		4 (2x)	9.84	2 (2x)	4.28	14.12	6 (2x)	14.76	2 (2x)	4.28	19.04
8.3.50.f		4 (2x)	9.84	2 (2x)	4.28	14.12	8 (2x)	19.68	2 (2x)	4.28	23.96
1.3.50.f		6 (2x)	14.76	2 (2x)	4.28	19.04	10 (2x)	24.60	2 (2x)	4.28	28.88
3.3.56.f	Ø560	4 (2x)	10.32	2 (2x)	4.68	15.00	6 (2x)	15.48	2 (2x)	4.68	20.16
4.3.56.f		4 (2x)	10.32	2 (2x)	4.68	15.00	6 (2x)	15.48	2 (2x)	4.68	20.16
6.3.56.f		4 (2x)	10.32	2 (2x)	4.68	15.00	6 (2x)	15.48	2 (2x)	4.68	20.16
8.3.56.f		4 (2x)	10.32	2 (2x)	4.68	15.00	8 (2x)	20.64	2 (2x)	4.68	25.32
1.3.56.f		6 (2x)	15.48	2 (2x)	4.68	20.16	10 (2x)	25.80	2 (2x)	4.68	30.48
3.3.63.f	Ø630	4 (2x)	10.32	2 (2x)	4.68	15.00	6 (2x)	15.48	2 (2x)	4.68	20.16
4.3.63.f		4 (2x)	10.32	2 (2x)	4.68	15.00	6 (2x)	15.48	2 (2x)	4.68	20.16
6.3.63.f		4 (2x)	10.32	2 (2x)	4.68	15.00	6 (2x)	15.48	2 (2x)	4.68	20.16
8.3.63.f		6 (2x)	15.48	2 (2x)	4.68	20.16	10 (2x)	25.80	2 (2x)	4.68	30.48
1.3.63.f		6 (2x)	15.48	2 (2x)	4.68	20.16	10 (2x)	25.80	2 (2x)	4.68	30.48

f = fin spacing

DVS Electrical defrost

Type	Fan	Light defrost					Heavy defrost				
		Coil (230V)		Drip tray (200V)		Total	Coil (230V)		Drip tray (200V)		Total
		number	kW	number	kW	kW	number	kW	number	kW	kW



4 fans

3.4.45.f	Ø450	2 (2x)	8.80	1 (2x)	3.74	12.54	3 (2x)	13.20	1 (2x)	3.74	16.94
4.4.45.f		2 (2x)	8.80	1 (2x)	3.74	12.54	3 (2x)	13.20	1 (2x)	3.74	16.94
6.4.45.f		2 (2x)	8.80	1 (2x)	3.74	12.54	3 (2x)	13.20	1 (2x)	3.74	16.94
8.4.45.f		2 (2x)	8.80	1 (2x)	3.74	12.54	4 (2x)	17.60	1 (2x)	3.74	21.34
1.4.45.f		3 (2x)	13.20	1 (2x)	3.92	17.12	5 (2x)	22.00	1 (2x)	3.92	25.92
3.4.50.f	Ø500	4 (2x)	12.40	2 (2x)	5.48	17.88	6 (2x)	18.60	2 (2x)	5.48	24.08
4.4.50.f		4 (2x)	12.40	2 (2x)	5.48	17.88	6 (2x)	18.60	2 (2x)	5.48	24.08
6.4.50.f		4 (2x)	12.40	2 (2x)	5.48	17.88	6 (2x)	18.60	2 (2x)	5.48	24.08
8.4.50.f		4 (2x)	12.40	2 (2x)	5.48	17.88	8 (2x)	24.80	2 (2x)	5.48	30.28
1.4.50.f		6 (2x)	18.60	2 (2x)	5.48	24.08	10 (2x)	31.00	2 (2x)	5.48	36.48
3.4.56.f	Ø560	4 (2x)	14.48	2 (2x)	5.84	20.32	6 (2x)	21.72	2 (2x)	5.84	27.56
4.4.56.f		4 (2x)	14.48	2 (2x)	5.84	20.32	6 (2x)	21.72	2 (2x)	5.84	27.56
6.4.56.f		4 (2x)	14.48	2 (2x)	5.84	20.32	6 (2x)	21.72	2 (2x)	5.84	27.56
8.4.56.f		4 (2x)	14.48	2 (2x)	5.84	20.32	8 (2x)	28.96	2 (2x)	5.84	34.80
1.4.56.f		6 (2x)	21.72	2 (2x)	5.84	27.56	10 (2x)	36.20	2 (2x)	5.84	42.04
3.4.63.f	Ø630	4 (2x)	14.48	2 (2x)	5.84	20.32	6 (2x)	21.72	2 (2x)	5.84	27.56
4.4.63.f		4 (2x)	14.48	2 (2x)	5.84	20.32	6 (2x)	21.72	2 (2x)	5.84	27.56
6.4.63.f		4 (2x)	14.48	2 (2x)	5.84	20.32	6 (2x)	21.72	2 (2x)	5.84	27.56
8.4.63.f		6 (2x)	21.72	2 (2x)	5.84	27.56	10 (2x)	36.20	2 (2x)	5.84	42.04
1.4.63.f		6 (2x)	21.72	2 (2x)	5.84	27.56	10 (2x)	36.20	2 (2x)	5.84	42.04



5 fans

3.5.50.f	Ø500	4 (2x)	15.52	2 (2x)	6.68	22.20	6 (2x)	23.28	2 (2x)	6.68	29.96
4.5.50.f		4 (2x)	15.52	2 (2x)	6.68	22.20	6 (2x)	23.28	2 (2x)	6.68	29.96
6.5.50.f		4 (2x)	15.52	2 (2x)	6.68	22.20	6 (2x)	23.28	2 (2x)	6.68	29.96
8.5.50.f		4 (2x)	15.52	2 (2x)	6.68	22.20	8 (2x)	31.04	2 (2x)	6.68	37.72
1.5.50.f		6 (2x)	23.28	2 (2x)	6.68	29.96	10 (2x)	38.80	2 (2x)	6.68	45.48
3.5.56.f	Ø560	4 (2x)	17.60	2 (2x)	7.04	24.64	6 (2x)	26.40	2 (2x)	7.04	33.44
4.5.56.f		4 (2x)	17.60	2 (2x)	7.04	24.64	6 (2x)	26.40	2 (2x)	7.04	33.44
6.5.56.f		4 (2x)	17.60	2 (2x)	7.04	24.64	6 (2x)	26.40	2 (2x)	7.04	33.44
8.5.56.f		4 (2x)	17.60	2 (2x)	7.04	24.64	8 (2x)	35.20	2 (2x)	7.04	42.24
1.5.56.f		6 (2x)	26.40	2 (2x)	7.04	33.44	10 (2x)	44.00	2 (2x)	7.04	51.04
3.5.63.f	Ø630	4 (2x)	17.60	2 (2x)	7.04	24.64	6 (2x)	26.40	2 (2x)	7.04	33.44
4.5.63.f		4 (2x)	17.60	2 (2x)	7.04	24.64	6 (2x)	26.40	2 (2x)	7.04	33.44
6.5.63.f		4 (2x)	17.60	2 (2x)	7.04	24.64	6 (2x)	26.40	2 (2x)	7.04	33.44
8.5.63.f		6 (2x)	26.40	2 (2x)	7.04	33.44	10 (2x)	44.00	2 (2x)	7.04	51.04
1.5.63.f		6 (2x)	26.40	2 (2x)	7.04	33.44	10 (2x)	44.00	2 (2x)	7.04	51.04



6 fans

3.6.50.f	Ø500	4 (2x)	18.64	2 (2x)	7.84	26.48	6 (2x)	27.96	2 (2x)	7.84	35.80
4.6.50.f		4 (2x)	18.64	2 (2x)	7.84	26.48	6 (2x)	27.96	2 (2x)	7.84	35.80
6.6.50.f		4 (2x)	18.64	2 (2x)	7.84	26.48	6 (2x)	27.96	2 (2x)	7.84	35.80
8.6.50.f		4 (2x)	18.64	2 (2x)	7.84	26.48	8 (2x)	37.28	2 (2x)	7.84	45.12
1.6.50.f		6 (2x)	27.96	2 (2x)	7.84	35.80	10 (2x)	46.60	2 (2x)	7.84	54.44
3.6.56.f	Ø560	4 (2x)	20.80	2 (2x)	8.32	29.12	6 (2x)	31.20	2 (2x)	8.32	39.52
4.6.56.f		4 (2x)	20.80	2 (2x)	8.32	29.12	6 (2x)	31.20	2 (2x)	8.32	39.52
6.6.56.f		4 (2x)	20.80	2 (2x)	8.32	29.12	6 (2x)	31.20	2 (2x)	8.32	39.52
8.6.56.f		4 (2x)	20.80	2 (2x)	8.32	29.12	8 (2x)	41.60	2 (2x)	8.32	49.92
1.6.56.f		6 (2x)	31.40	2 (2x)	8.32	39.52	10 (2x)	52.00	2 (2x)	8.32	60.32
3.6.63.f	Ø630	4 (2x)	20.80	2 (2x)	8.32	29.12	6 (2x)	31.20	2 (2x)	8.32	39.52
4.6.63.f		4 (2x)	20.80	2 (2x)	8.32	29.12	6 (2x)	31.20	2 (2x)	8.32	39.52
6.6.63.f		4 (2x)	20.80	2 (2x)	8.32	29.12	6 (2x)	31.20	2 (2x)	8.32	39.52
8.6.63.f		6 (2x)	31.40	2 (2x)	8.32	39.52	10 (2x)	52.00	2 (2x)	8.32	60.32
1.6.63.f		6 (2x)	31.70	2 (2x)	8.32	39.52	10 (2x)	52.00	2 (2x)	8.32	60.32

f = fin spacing

Goedhart standard product information

Goedhart standard aircooler overview



VCI



DVS/DRS/DZS



ZGB/ZGZ



PAC



FC38



ZFB/ZFZ



Goedhart air cooler for every application

For Contractors and Original Equipment Manufacturers (OEM) related to the industrial refrigeration industry, GEA Goedhart B.V. offers an unlimited range of air coolers and air cooled condensers in several configurations.

Depending on the application, the optimum configuration will be selected in close cooperation with our customers.

Configurations

The following material combinations are available in various tube pitches and various fin spacing:

Tube material	Tube configuration	Fin material
Copper (Cu)	38x33, 50x50, 60x60	Aluminium (Al)
Stainless steel (Stst)	38x33, 50x50, 60x60	Aluminium (Al)
Stainless steel (Stst)	50x50	Stainless steel (Stst)
Aluminium (Al)	60x60	Aluminium (Al)
Hot dipped galvanized steel (FeZn)	60x60, 75x75	Hot dipped galvanized steel (FeZn)

Options on aluminium fins

- Goldlack coated fins
- Seawater resistant aluminium fins (AlMg)

Applications

Cooling	Freezing
Cold stores / Distribution centres	Cold stores / Distribution centres
Food processing rooms	Tunnel / spiral freezers
Fruit storage	Slaughter houses
Banana ripening storage	Automotive testing rooms
Greenhouse conditioning	Ski domes

Pressure Equipment Directive (P.E.D.)

All aircoolers produced by Goedhart comply with the Pressure Equipment Directive 97/23/EC. PED certificates can be downloaded from www.goedhart.nl.





GEA Heat Exchangers

GEA Goedhart B.V.

Nijverheidsweg 6, 4695 RC Sint Maartensdijk
the Netherlands
Phone +31 (0)166 665 665, Fax+31 (0)166 663 698
www.goedhart.nl
info.goedhart.nl@geagroup.com

GEA Heat Exchangers

GEA Goedhart s.r.o.

Kostomlátecká 180, 288 26 Nymburk
Czech Republic
Phone +420 (0)325 819 951, Fax+420 (0)325 519 952
www.goedhart.cz
goedhart.cz@geagroup.com

03.01.2.009.doc 2010-01 / Subject to modification

All offers, contracts, deliveries and other legal relations from GEA Goedhart B.V. are subject to the latest version of our general sales and delivery conditions as filed at the Chamber of Commerce in Middelburg - The Netherlands

Applicability of the general conditions put forward by any buyer is rejected explicitly by GEA Goedhart B.V.